

ARBEITSMASSAEN DEN BÖSCHUNGSMÄHER

DIMENSIONI DI LAVORO BRACCI DECESPUGLIATORI / WORKING DIMENSIONS OF THE HYDRAULIC ARMS

DIMENSION D'EXECUTION BRAS DE DEBROUSSAILLAGE / DIMENSIONES DE TRABAJO BRAZOS DESMALEZADORES

STANDARD

MODEL	A cm	B cm	C cm	D cm	E cm	F cm	G cm	H cm	I cm	L cm	M cm	N cm	O cm
HB 310	321	132	54	140	203	428	326	219	166	111	80	-	157
HB 3500	336	145	67	153	216	428	326	209	166	101	80	-	147
HBS 4000	455	190	95	110	250	470	360	295	170	181	105	160	260
HBS 4500	440	204	54	140	216	547	409	306	197	195	125	-	276
HBS 4550	440	204	54	140	216	547	409	306	197	195	125	-	276
HBK 5000	508	192	152	140	150	492	376	324	150	262	105	212	370
HBK 6000	602	210	148	144	150	586	454	391	163	275	125	227	390
HBP 5050	508	192	152	140	150	492	376	324	150	262	105	212	370
HBP 6050	602	210	148	144	150	586	454	391	163	275	125	227	390
HBT 8000 T	780	665	-	-	-	795	570	-	-	-	125	-	665
HBT 10500 T	1020	855	-	-	-	975	700	-	-	-	125	-	855

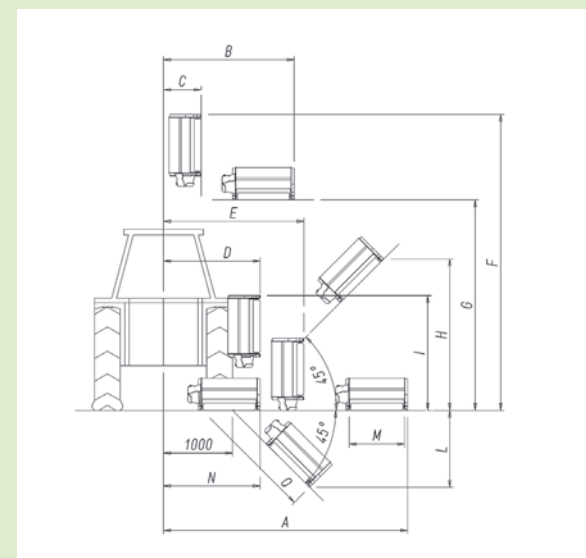

ADVANCED

MODEL	A cm	B cm	C cm	D cm	E cm	F cm	G cm	H cm	I cm	L cm	M cm	N cm	O cm	P cm	Q cm	R cm	S cm	T cm
HBA 5600	540	180	175	-	-	460	320	-	-	-	125	-	-	195	460	75	135	210
HBA 6400	630	200	180	-	-	510	370	-	-	-	125	-	-	210	515	75	195	230

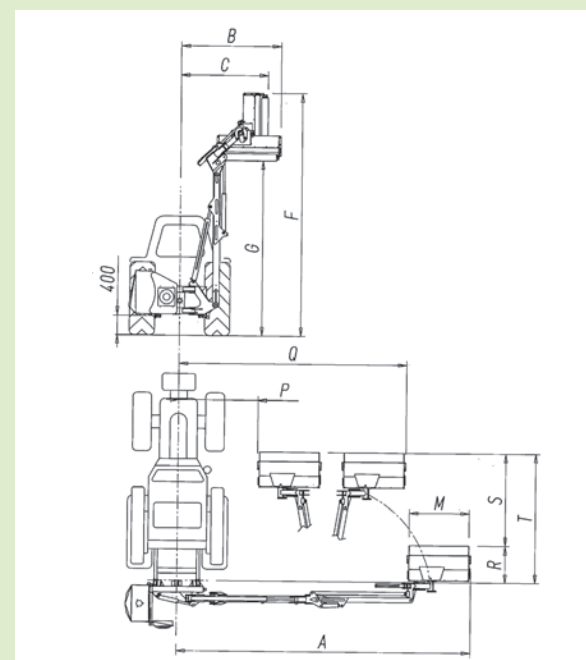

PARALLEL

MODEL	A cm	B cm	C cm	D cm	E cm	F cm	G cm	H cm	I cm	L cm	M cm	N cm	O cm
HBR 4600	485	234	195	153	-	555	429	318	-	206	125	-	296
HBZ 5000	510	247	220	154	137	570	430	360	215	250	125	210	355
HBZ 5500	560	-	-	-	150	662	536	396	-	275	125	200	390
HBZ 6500 T	651	-	-	-	150	746	620	463	-	341	125	200	483