









# TWO-C

1300 | 1600 | 2000

- IMPIEGO:** Per tralci di vite, erba, legna e sarmenti di media dimensione
- USE:** For vineyard, orchard, grass, wood, pruning and medium size branches
- EMPLOI:** Pour broyer herbe, bois, buissons et sarments de moyenne dimension
- ANWENDUNG:** Für Rebholz, Grass, Holz und Rückstände mittlerer Größe
- UTILIZACION:** Para hierba, sarmentos de viña, madera, ramas de media dimensiones

MODEL								
TWO-C 1300	126	6/8	12	4	1390	II	50	540
TWO-C 1600	154	8/10	12	4	1650	II	50	540
TWO-C 2000	201	8/10	16	4	1880	II	50	540



- TENDICATENA
- CHAIN TENSIONER
- TENDEUR DE CHAÎNE
- KEILRIEMENSPIANNER
- SENSOR DE CADENA



- TENDICINGHIA
- BELT TENSIONER
- TENDEUR DE COURROIES
- SPANNWELLE
- TENSOR DE CORREA

**VELOCITÀ PERIFERICA DEGLI UTENSILI**  
TIP SPEED OF TOOLS  
VITESSE PÉRIPHÉRIQUE DES OUTILS  
WERKZEUGUMFANGSGESCHWINDIGKEIT  
VELOCIDAD PERIFÉRICA DE HERRAMIENTAS

m/sec	60.53		
	MODEL	A mm	B mm
	TWO-C 1300	194x8	409
	TWO-C 1600-2000	194x10	413

## EQUIPAGGIAMENTO DI SERIE STANDARD EQUIPMENT DE SÉRIE STANDARDAUSSTATTUNG ACESORIOS DE SERIE

■ DOPPIO TELAIO	■ DOUBLE FRAME	■ DOUBLE CHASSIS	■ DOPPELTER RAHMEN	■ DOBLE BASTIDOR
LAMIERE INTERNE HARDOX 500 DUE FILE DI CONTROLLO COLTELLI TRANSMISSIONE MECCANICA A CATENA LIMITATORE DI COPPIA AUTOMATICO RUOTA LIBERA NEL GRUPPO RACCOLTITORE / TELAIO CON IMP. IDRAULICO DI SOLLEVAMENTO TENDICATENA TENDICINGHIA CATARIFRANGENTI RUOTE	INNER SHEET HARDOX 500 TWO STATIC KNIVES MECHANICAL CHAIN TRANSMISSION AUTOMATIC TORQUE LIMITER FREE WHEEL IN THE GEARBOX COLLECTOR W/UNLOADING HYDR. SYSTEM CHAIN TENSIONER BELT TENSIONER REFLECTORS WHEELS	TOILES INTERIEURES EN HARDOX 500 DEUX CONTRE COUTEAUX TRANSMISS. PAR CHAÎNE MECANIQUE LIMITEUR DE COUPLE AUTOMATIQUE ROUE LIBRE DANS LE BOUTIER BAC DE RECOLTE AVEC CHÂSSIS, INSTALLATION HYDRAULIQUE TENDEUR DE CHAÎNE TENDEUR DE COURROIES REFLECTEURS ROUES	INENNRÄHMEN AUS STAHL HARDOX 500 ZWEI REIHEN VON GEGENLEISTEN AUF DER HECKKLAPPE MECHAN. KETTENTRIEB AUTOMAT. KEILRIEMENSPIANNER FREILAUF IM GETRIEBE SAMMELBEHÄLTER MIT HYDR. HEBESYSTEM KEILRIEMENSPIANNER SPANNWELLE REFLEKTOREN RÄDER	CHAPA INTERNA EN ACERO HARDOX 500 DOS CONTRA-CUCHILLA TRANSMIS. PARA CADENA, MECANICA LIMITADOR DE PAR AUTOMATICO RUEDA LIBRE EN LOS ENGRANAJES RECOGEDOR CON SISTEMA HIDRAULICO DE DESCARGA TENSOR DE CADENA TENSOR DE CORREA REFLECTORES RUEDAS

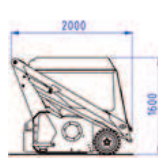
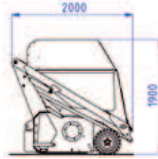
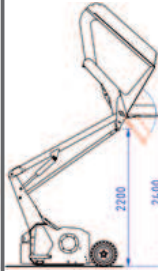

OPTIONAL				
			<b>OPTIONAL</b> ■ RACCOLTITORE MAGGIORATO BIG COLLECTOR ■ GRAND BAC DE RECOLTE GROSSER SAMMELBEHÄLTER ■ RECOGEDOR GRANDE	
MODEL	Kg	m <sup>3</sup>	Kg	m <sup>3</sup>
TWO-C 1300	1300	1.2	1420	1.5
TWO-C 1600	1650	1.5	1690	1.9
TWO-C 2000	1880	1.9	1930	2.4
<b>INGOMBRO IN LARGHEZZA</b> ■ WIDTH ■ BREITE ■ LARGEUR ■ ANCHURA				
<b>TUTTI I MODELLI</b> ■ ALL MODELS ■ ALLE MODELLE ■ TOUS LE MODELS ■ TODOS LOS MODELOS				

## OPTIONAL



- TIMONE DI TRAINO
- TOWING RUDDER
- SCHLEPPENSTEUER
- TIMON POUR LE TRANSPORT
- TIMON DE REMOLQUE



- RULLO Ø 195 mm
- ROLLER Ø 195 mm
- ROULEAU Ø 195 mm
- WALZE Ø 195 mm
- RODILLO Ø 195 mm



- KIT TRASMISSIONE IDR. PICKUP CON DIVISORE DI FLUSSO E VALVOLA DI MAX DOPPIA
- KIT HYDR. TRANSMISS. PICK-UP + FLOW DIVIDER + DOBLE MAX PRESSURE VALVE
- KIT TRANSMISS. HYDR. PICK-UP + DIVISEUR DEBIT ET SOUPAPE DOUBLE MAX PRESSURE
- HYDR. ANTRIEB VOM PICK-UP + FLUSSREGELVENTIL UND DOPPELTEM MAX. VENTIL
- KIT TRANSMISION IDR. PICK-UP CON DIVISEUR FLUIDO Y DOBLE VALVULA MAX PRESS.



- CARDANO
- PTO SHAFT
- CARDAN
- GELLENKWELLE
- CARDAN

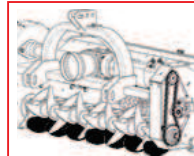

- KIT SASSI
- KIT FOR STONES
- KIT POUR CAILLoux
- RICHTUNGSKUFEN
- KIT PARA PIEDRAS



- GRIGLIA DI SMINUZAMENTO
- KIT MULCHING
- GRILLE MULCHING
- SATZ MULCHING
- KIT MULCHING



- SLITTE DI DIREZIONE
- DIRECTION SKIDS
- PATINS DE DIRECTION
- RICHTUNGSKUFEN
- PATINES DE DIRECTION

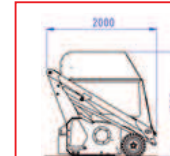

- RACCOLTITORE MAGGIORATO
- BIG COLLECTOR
- GRAND BAC DE RECOLTE
- GROSSER SAMMELBEHÄLTER
- RECOGEDOR GRANDE

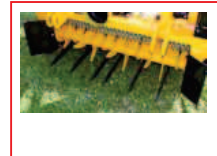

- CONVOGLIATORI ANTERIORI
- FRONT VANES
- AILETTES FRONTALES
- FRONTLÜGEL
- ALETAS ANTERIORAS